

FT Series Fintube® Air Heaters Overview

- Many Sheath and Fin Materials Available
- 475 - 10,000 Watts
- 120, 240 and 480 Volt
- 750 to 900°F Max. Sheath Temp.

Applications

- Drying
- Heat Treating
- Annealing
- Load Banks
- Curing Ovens, Dryers, Ducts, etc.

Features

Versatile — Ideal for both comfort and industrial process air applications. Aluminum painted steel (FTS), MONEL® (FTI) or Stainless Steel (FTSS) sheath and fin material are available. Contact your Local Chromalox Sales office for price and availability.

Fins greatly increase surface area and permit faster heat transfer to the air, resulting in lower element surface temperatures.

Construction — Element is constructed like the standard tubular element with the addition of continuous spiral fins (4 - 5 per inch) permanently furnace brazed to the sheath.

High Watt Density permits use of fewer elements or higher concentration of installed kW for a given area.

Figure 1 — Dimensions (Inches)

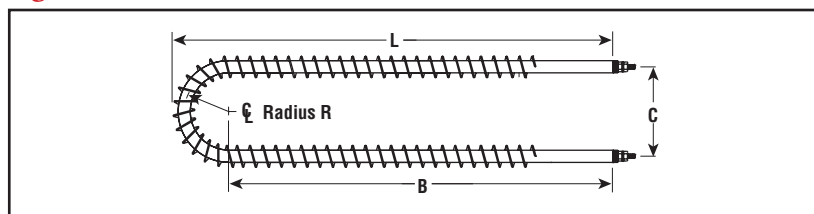
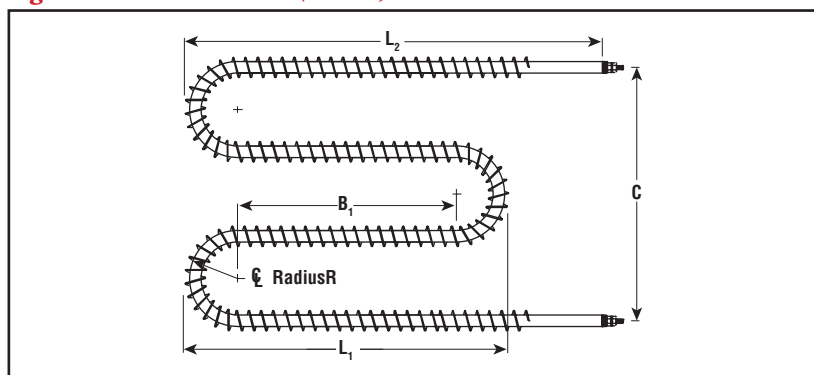

Figure 2 — Dimensions (Inches)



Easy Installation — Bending configurations can be designed to fit either round or rectangular ducts. Tight element bends are repressed in hydraulic presses after bending to assure recompaction of refractory material to eliminate hot spots and electrical insulation voids.

Power Connections should be made with alloy wire.

Overtemperature Protection — A high limit temperature cutout is recommended.

Bending — Fintube® elements may be field or factory bent according to the following parameters:

Factory & Customer Bending (In.)

| Element Dia. (In.) | Min. Factory | | Min. Customer | |
|--------------------|--------------|---|---------------|---------|
| | C | R | C | R |
| Figure 1 | | | | |
| 0.315 | 2 | 1 | 2-5/16 | 1-5/32 |
| 0.475 | 2 | 1 | 3-3/8 | 1-11/16 |
| Figure 2 | | | | |
| 0.315 | 6 | 1 | 6-15/16 | 1-5/32 |
| 0.475 | 6 | 1 | 10-1/8 | 1-11/16 |

Note — The start of any bends should be no closer than 3-7/16" for 0.475" dia. or 3-5/8" for 0.315" dia. elements, from the end of the sheath to prevent the heating element/cold pin junction from being located in a bend.

Special Features — Sheath material (i.e. Stainless Steel), threaded fittings, length, diameter, volts, watts, special bends, terminals, terminal enclosures, brackets, spacers, etc. Contact your Local Chromalox Sales office for price and availability.

Standard Terminal Construction

Standard Terminal Construction — Type 3 terminals are standard on 0.315" diameter sheaths and Type 4 terminals for 0.475" diameter sheaths.

Type 3 Terminal — Dimensions (In.)

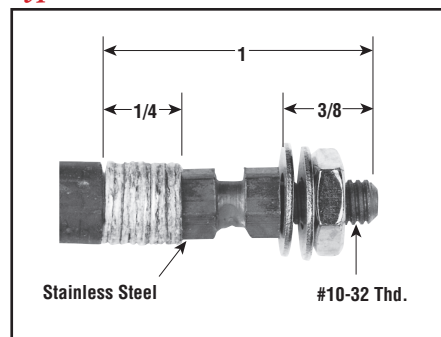

Type 4 Terminal — Dimensions (In.)

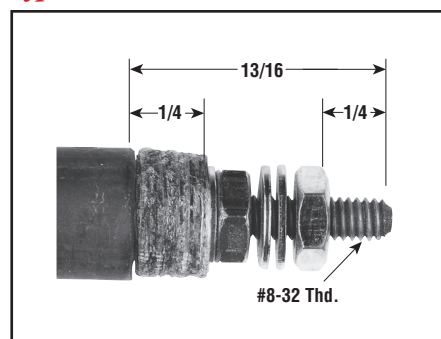

Special Terminal Construction — Many types of terminals are available to suit different applications. See Tubular section in this catalog for selection.

